



TEST REPORT

Report No.: STE11032546S

Product: 16INCH STAND FAN

Model No.: FS40-1A, (others refer to page 2)

Prepared for: ZhongShan Double Crown Electrical Appliance Co., Ltd

Address: NO.10 JIANLONG STREET JIDONGER INDUSTRIAL ZONE, XIAOLAN TOWN,
ZHONGSHAN, CHINA

Prepared by: Shenzhen STE Testing Laboratory Co., Ltd.

Lab Location: 3/F, Building 9, Hongde Factory, No. 63 Yuchang Road, NiuHu Community,
Guanlan Street, Longhua District, Shenzhen, China

Tel. : +86-755-2373 0717

Fax. : +86-755-2373 0717

Website: <http://www.stecert.com>

This test report may be duplicated completely for legal use with the approval of the applicant. It should not be reproduced except in full, without the written approval of our laboratory. The test results in the report only apply to the tested sample. Any objections must be raised to STE within 15 days since the date.

TEST REPORT**for ERP**

- for comfort fans Ecodesign requirements for air conditioners and
- comfort fans Implementation measure EU 206/2012

Report Number.....: STE11032546S

Tested by (name + signature).....: Plum Xiao / Test engineer

Approved by (name + signature).....: Allen Huang / Project manager

Date of issue.....: November 20, 2025

Total number of pages.....: 13



Testing Laboratory: Shenzhen STE Testing Laboratory Co., Ltd.

Address: 3/F, Building 9, Hongde Factory, No. 63 Yuchang Road, Niuhu Community, Guanlan Street, Longhua District, Shenzhen, China

Applicant's name.....: ZhongShan Double Crown Electrical Appliance Co., Ltd

Address.....: NO.10 JIANLONG STREET JIDONGER INDUSTRIAL ZONE, XIAOLAN TOWN, ZHONGSHAN, CHINA

Manufacturer's name.....: ZhongShan Double Crown Electrical Appliance Co., Ltd

Address.....: NO.10 JIANLONG STREET JIDONGER INDUSTRIAL ZONE, XIAOLAN TOWN, ZHONGSHAN, CHINA

Test item description.....: 16INCH STAND FAN

Trade Mark.....: DOUBLE CROWN

Model/Type reference.....: FS40-1A, FS40-4, FS40-9, FS40-10

Ratings.....: Input: 220-240V~, 50Hz, 40W

Copyright © 2025 Shenzhen STE Testing Laboratory Co., Ltd. All rights reserved.

Test specification:Standard.....: EN 50564: 2011
EN IEC 60879: 2019
EN IEC 60704-1: 2021
EN IEC 60704-2-7: 2020Test procedure.....: Commission Regulation (EC) No. 206/2012 Implementing Directive 2009/125/EC of the European Parliament and of the Council with regard to ecodesign requirements for air conditioners and comfort fans
 Commission Regulation (EC) No. 1275/2008 implementing Directive 2009/125/EC with regard to ecodesign requirement for standby and off mode electric power consumption of electrical and

electronic household and office equipment

- Commission Regulation (EU) 2023/826 of 17 April 2023 laying down ecodesign requirements for off mode, standby mode, and networked standby energy consumption of electrical and electronic household and office equipment pursuant to Directive 2009/125/EC of the European Parliament and of the Council and repealing Commission Regulations (EC) No 1275/2008 and (EC) No 107/2009
- (EU) 2016/2282 amending Regulations with regard to the use of tolerances in verification procedures

Non-standard test method.....: N/A



Possible test case verdicts:

- test case does not apply to the test object..... : N or N/A (Not Applicable)
- test object does meet the requirement..... : P (Pass)
- test object does not meet the requirement..... : F (Fail)

Testing..... :

Date of receipt of test item..... : November 18, 2025

Date (s) of performance of tests..... : November 18, 2025 to November 20, 2025

Type of test object..... : Portable appliance

Order descriptions..... :

<input checked="" type="checkbox"/>	Complete test according to TFR
<input type="checkbox"/>	Partial test according to manufacturer's specifications
<input type="checkbox"/>	Preliminary test
<input type="checkbox"/>	Spot check
<input type="checkbox"/>	Others

Test item particulars:

Nominal electric power (PN)..... : [W] Fan power: 40W

Diameter of blade sweep.....:[cm] 48mm

Number of blades..... : 3

Type of fans acc. to mounting..... :

<input type="checkbox"/> Ceiling fans	<input type="checkbox"/> Fans
<input type="checkbox"/> Deck-head fans	<input type="checkbox"/> Box fans
<input type="checkbox"/> Table fans	<input checked="" type="checkbox"/> Floor standing fans
<input type="checkbox"/> Pedestal fans	<input type="checkbox"/> Other fans

Type of fans acc. to function..... : Non-oscillating / Oscillating

Number of regulated speed..... : 6 speeds

Summary of testing:

Testing location:

Shenzhen STE Testing Laboratory Co., Ltd.

3/F, Building 9, Hongde Factory, No. 63 Yuchang Road, Niuhu Community, Guanlan Street, Longhua District, Shenzhen, China

Tests performed (name of test and test clause):

- EN IEC 60879: 2019
- EN 50564:2011
- EN IEC 60704-1: 2021
- EN IEC 60704-2-7: 2020

General remarks

"(see remark #)" refers to a remark appended to the report.

"(see appended table)" refers to a table appended to the report.

Throughout this report a comma is used as the decimal separator.

The test results presented in this report relate only to the object tested.

This report shall not be reproduced except in full without the written approval of the testing laboratory.

Copy of marking plate:



Summary of testing:

- 1, The product meets the Stage 2 (1 January 2014) requirement of the implementation measure.
- 2, The manufacturer shall draw up the technical documentation, provided information of free access websites and have laboratories information available acc. to (EC) No. 206/2012 Annex I item 3 (a) and 3 (b)
- 3, Tested items are fan for household use only.
- 4, All models are same except the color. Tests carried on model FS40-1A as worst conditions.
- 5, The laboratory tests and evaluates the main model. Adding models based on the guarantee letter provided by the Applicant. STE takes no responsibility for any mistakes and the problems of product consistency caused by inaccurate and/or invalid information submitted by the Applicant.

EN 50564: 2011			
Clause	Requirement – Test	Result - Remark	Verdict

<p>TEST REPORT EN 50564 Electrical and electronic household and office equipment - Measurement of low power consumption</p>
--

	Measurement of Standby & Off Power EN 50564:2011		--
4	General conditions for measurements		--
4.2	Test room		--
	Ambient condition met requirement of: Ambient temperature (23 ±5)°C Airspeed <0.5m/s	Ambient temperature: 24.1°C Airspeed < 0.2m/s	P
	Where the product has an ambient light sensor that affects the power consumption, the test shall be carried out with controlled ambient light conditions. Where the illuminance levels are externally defined (in a test procedure or in the instructions for use), these values shall be used. Where no illuminance levels are stated or defined, reference illuminance levels of >300 lx and <10 lx shall be used. (EN 50564 cl.4.2)		N
4.3	Power supply		--
4.3.1	Supply voltage and frequency		P
	For single phase products, • 230 V ± 1%, • 50 Hz ± 1%.	230V, 50Hz	P
	For three-phase products, • 400 V ± 1%, • 50 Hz ± 1%.		N
4.3.1	Supply voltage waveform	Harmonic content ≤ 2%	P
4.4	Power measuring instruments		--
4.4.1	Power measurement uncertainty		--
	Measurements of power of 0.5 W or greater shall be made with an uncertainty of less than or equal to 2 % at the 95 % confidence level.		P
	Measurements of power of less than 0.5 W shall be made with an uncertainty of less than or equal to 0.01 W at the 95 % confidence level.		P

5	Measurements		--
5.3	Test approach used		
5.3.2	- Sampling method Note: to be used when power is not stable (cyclic or unstable) or limited		P

EN 50564: 2011			
Clause	Requirement – Test	Result - Remark	Verdict
5.3.3	- Average reading method Note: to be used when power and mode is stable		N
	--Average power approach		N
	--Accumulated energy approach		N
	Direct meter reading method Note: to be used when power and mode is stable, not for verification purposes (EN 50564 cl.5.3.4)		N
0.6	Test circuit		--
	Test circuit acc. to Fig.1 is used		P
	Other test circuit is used		N

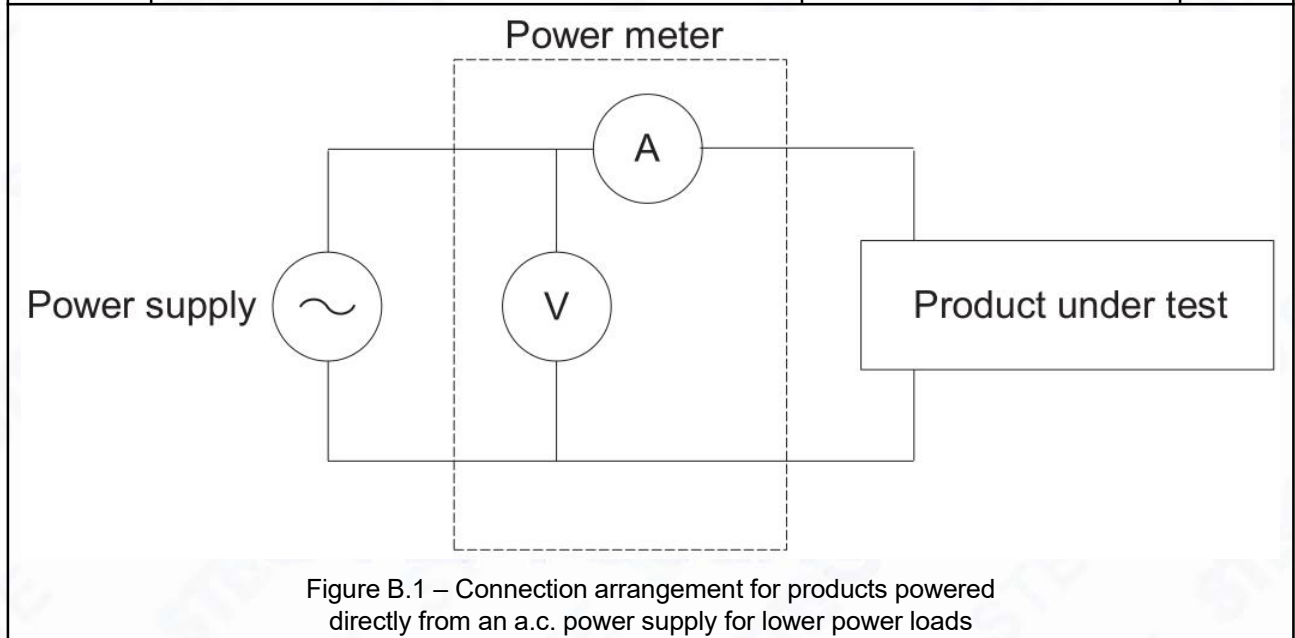

EN 50564: 2011			
Clause	Requirement – Test	Result - Remark	Verdict

1, Maximum power consumption in off-mode and standby mode for comfort fans according to EN 50564:2011

Requirements referred in Regulation (EC) no. 206/2012	
<input type="checkbox"/> Deadline for compliance – Stage 1	January 01, 2013
<input checked="" type="checkbox"/> Deadline for compliance – Stage 2	January 01, 2014

Requirements referred in Regulation (EC) no.1275/2008 & (EU) no.801/2013	
<input type="checkbox"/> Deadline for compliance – Stage 1	January 07, 2010
<input checked="" type="checkbox"/> Deadline for compliance – Stage 2	January 07, 2013

1.1 Availability of off-mode and/or standby mode

Availability of stand-by mode and/or off mode or any equivalent conditions as defined in the Commission Regulation (EU) 2023/826	<input checked="" type="checkbox"/> Yes	<input type="checkbox"/> No
Function compulsory	<input checked="" type="checkbox"/> Yes	<input type="checkbox"/> No
Verdict	<input checked="" type="checkbox"/> PASS	<input type="checkbox"/> Fail

1.2 Power consumption for stage 1 requirement:

Mode	Measure	Requirement	Verdict
Standby mode With only reactivation function OR only reactivation function + mere indication of enabled reactivation function	--	1W	N
Standby mode With only information or status display OR only information or status display + reactivation function	--	2W	N
Off mode	--	1W	N

1.3 Power consumption for stage 2 requirement: FS40-1A

Mode	Measure	Requirement	Verdict
Standby mode With only reactivation function OR only reactivation function + mere indication of enabled reactivation function	--	0.5 W	P
Standby mode With only information or status display OR only information or status display + reactivation function	--	1 W	N
Off mode	0.01W	0.5 W	P

ERP for comfort fans			
Clause	Requirement – Test	Result - Remark	Verdict

<p align="center">TEST REPORT EN IEC 60879 Comfort fans and regulators for household and similar purposes - Methods for measuring performance</p>			
	Measurement of Airflow and Power		--
5	Tests		--
5.1	General conditions for testing		P
5.1.1	Atmospheric conditions		P
	-- temperature: 20 °C ± 5°C	24.1°C	P
	-- relative humidity: 50 % ± 30 %	56%RH	P
	-- air pressure: 86 kPa to 106 kPa.	95.3 kPa	P
5.1.2	Conditioning of test equipment		P
	stored for at least 16 h at the atmospheric conditions specified in 5.1 .1 prior to the test.		P
5.1.3	Voltage and frequency		--
	The tests shall be conducted at the rated voltage.	230V	P
	Fans designed for DC only shall be operated at DC.		N
	Fans designed for both AC and DC shall be operated at AC.		N
	Fans not marked with rated frequency shall be operated at either 50 Hz ± 1 Hz or 60 Hz ± 1 Hz as is common in the country of use and with a total harmonic distortion ≤ 5 %.		
	Tests are carried out at a specific test voltage within a voltage or at the rated voltage or rated voltages	230V	P
	The stability of the voltage shall be ± 1 %.		P
5.1.4	Running-in of the fan		--
	Operation for at least 1 hour to ensure adequate running-in		P
5.1.5	Operation of the fan		--
	Any controls shall be set for maximum continuous air flow unless the manufacturer's instruction states otherwise.		P
	Any other functions such as luminaires, purifiers, humidifiers, heaters, if any, shall be turned off.		P
5.1.6	Conditioning prior to each test		--
	Prior to starting each test, the fan shall be conditioned for 30 min under the provisions given in 5.1 .4		P

ERP for comfort fans			
Clause	Requirement – Test	Result - Remark	Verdict
5.2	Test for air performance		--
5.2.1	Ceiling fans		--
	Test chamber specified as figure 1 and 2	4.5*4.5*3m	N
	Height of fan [3±0.01 m]		N
	Testing instrument Vane anemometer having an internal diameter not exceeding 100mm		N
	Procedure for test		--
	Run-in to steady condition at test voltage		N
	Running at full speed at the test voltage		N
	Measure the air delivery (Maximum fan flow rate) as specified		N
5.2.2	Comfort fans other than ceiling fans		--
	Test chamber as specified	4.5*4.5*3m	P
	Distance to walls as specified		P
	Testing instrument Vane anemometer having an internal diameter not exceeding 100mm		P
	Arrangement of apparatus specified as:		--
	Figure 4, for pedestal fans		N
	Figure 5, for table fans		P
	Other test set-up		P
	Procedure for test		--
	Run-in to steady condition at test voltage		N
	Running at full speed at the test voltage		N
	Measure the air delivery (Maximum fan flow rate) as specified	See test data	P
5.6	Measurement of power factor (for a.c. fans only) and power input		--
	Supplied at the test voltage and frequency		P
	Set at highest speed		P
	Oscillating mechanism shall be in action		N
	Measured power input [W]	See test data	P

ERP for comfort fans			
Clause	Requirement – Test	Result - Remark	Verdict

2, Test data

From 1 January 2013, as regards comfort fans, the information set out in points above and calculated in accordance with Annex II of implementing measure (EC) No. 206/2012 shall be provided on:

- (5) the technical documentation of the product;
- (ii) free access websites of manufacturers of comfort fans;

Sample: FS40-1A

Information to identify the model(s) to which the information relates to [fill in as necessary]			
Description	Symbol	Value	Unit
Maximum fan flow rate	F	53.3	m ³ /min
Fan power input	P	56.2	W
Service Value	SV	0.95	(m ³ /min)/W
Standby power consumption	P _{SB}	/	W
Off power consumption	P _{off}	0.01	W
Fan sound power level	L _{WA}	50.5	dB(A)
Maximum air velocity	c	3.14	Meters/sec
Seasonal electricity consumption	Q	13.1	kWh/a
Measurement standard for service value	EN IEC 60879: 2019 Comfort fans and regulators for household and similar purposes - Methods for measuring performance		
Contacts details for obtaining more information	Name and address of the manufacturer or of its authorised representative.		
Note:			
1. The fan power input (P) have been performed at the maximum speed, no swinging or other function using;			
2. Test standards for sound power level are EN IEC 60704-1: 2021 & EN IEC 60704-2-7: 2020.			

Appendix tables

Test Equipment list:

Instrument Code	Instrument Type	Manufacturer	Model	Range Used	Calibration Date
					Calibration Due Date
STE-S-117	Digital Power Meter	YOKOGAWA	WT310	0-600Vac, 0-20A, 0-6000W	2025/01/09
					2026/01/08
STE-S-056	Digital multimeter	FLUKE	Fluke15B	0~1000Vdc, 0~10A, 0~20MΩ, 700Vac	2025/01/09
					2026/01/08
STE-S-029	Stop watch	TIANFU	PC396	0.01s-24h	2025/01/09
					2026/01/08
STE-S-187	Wind Anemometer	Taiwan Taishi	TES1341	0-25m/s	2025/01/09
					2026/01/08
STE-S-015	Temperature & Humidity recorder	SHANGHAI	ZJ1-2B	45-35°C, 30~100%RH	2025/01/09
					2026/01/08
STE-S-122	Electronic Loading	Ainuo	AN23103H	150Vdc, 60A, 300W	2025/01/09
					2026/01/08

Product Photos



Fig. 1



Fig. 2

----- END OF REPORT -----